

# CONTROL BOX ELECTRONICS SCHEMATICS

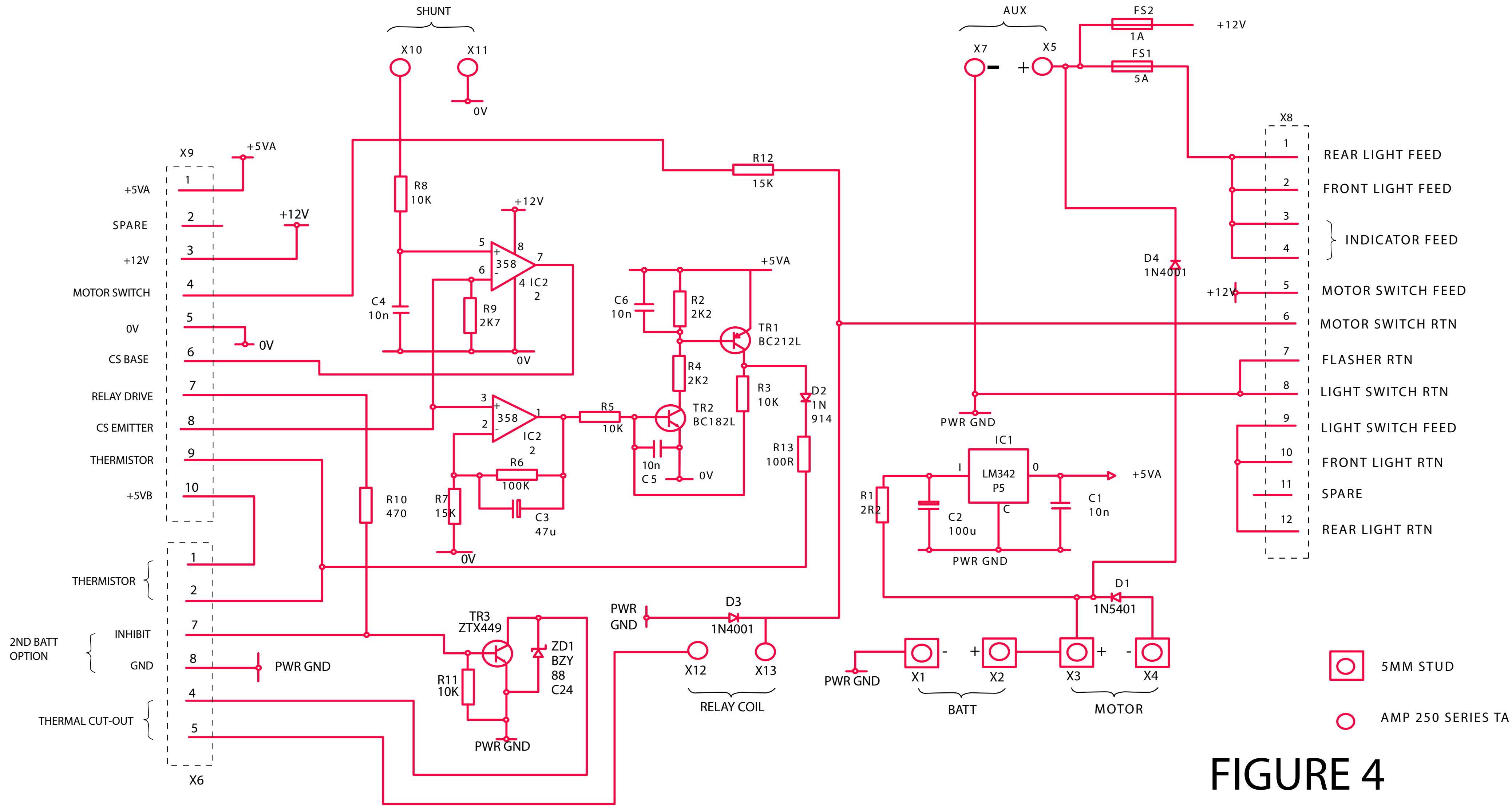

**FIGURE 4**

Re-drawn by Chris Gavin-Egan of C5alive.co.uk  
from drawings supplied by Roy Woodward of SinclairC5.com